

MEMBERSHIP INFORMATION

Dear Neighbors:

It is not too late to join the KPSH Neighborhood Association. We are still accepting dues for calendar year 2007. Just complete form below and mail to KPSHA P.O. Box 11762, Knoxville, TN 37939 Not sure if you've joined? There will be a membership listing available at the Labor Day Picnic.

Walk anywhere in the neighborhood and you can see the delights of nature and the history that surrounds us. Centuries of human history have endowed our community with a rich sense of place, from the Cherokee mounds on the Boulevard to the Civil War artifacts that children still occasionally find.

The board of our Kingston Pike/Sequoyah Hills Association has worked diligently during the past year on these issues and other issues:

- Neighborhood Conservation Overlay
- Neighborhood Watch
- Traffic Calming
- Zoning Regulations
- Code Violations
- Annual Labor Day Picnic

As you can see, the Kingston/Pike Sequoyah Hills Association is active throughout the year in serving the interest of our community. We need your help; your membership and contribution will further the work of the association, and help protect and improve this wonderful community. Please send your \$35 today. Your canceled check is your receipt. Thank you for your support.

Interested in joining the Board or one of its committees? Please show your preference on attached form.

KINGSTON/PIKE SEQUOYAH HILLS ASSOCIATION BOARD

Name: _____

Address: _____

City _____ State _____ Zipcode _____

Phone _____ E-mail _____

Dues \$ _____ Tax Deductible Contribution \$ _____ Total \$ _____

Committee or Board area of interest? _____

Kingston Pike / Sequoyah Hills Association

P.O. Box 11762 • Knoxville, TN 37939

KINGSTON PIKE / SEQUOYAH HILLS ASSOCIATION BOARD MEMBERS:

KPSHA Board Members
Jim Bletner, President, jbletner@utk.edu
Cliff Beach, VP, 50toes@comcast.net
Greg Penn, VP, gregp@foodsalseast.com
Beth Breazeale, Treasurer, bbreazeale@pyapc.com
Ellen Robinson, PR, erobinson@moxleycarmichael.com
Anne McIntyre, Secretary, amcintyr@utk.edu
Karen Britton, Membership, britton@utk.edu
Sandy Gillespie, Neighborhood Watch, sandyg222@hotmail.com
Tom Midyett, Government Relations, tmidyett@aol.com
Nancy Bills, Overlay, nbills@bellsouth.net
Nancy Lofaro, Overlay, lofaro@utk.edu
Valerie Coleman, Picnic, cvcoleman@comcas.net
Beth Schultheis, Newsletter, bcs4040@yahoo.com

Additional information:
Tom Heffernan & Raleigh Bacon, Memorial Trees
Raleigh Bacon, website

Non-Profit Org.
U.S. POSTAGE
PAID
Permit No. 475
Knoxville, TN



Kingston Pike Sequoyah Hills Association

P.O. Box 11762 • Knoxville, Tennessee 37939

September 2007

KPSHA ANNUAL LABOR DAY PICNIC

Monday, September 3rd, 2007

6:30 to 8:00 pm

Vance Link Baseball Park, Cherokee Blvd.
(FYI, Boomsday is scheduled for Sunday)

Please join us, young and young at heart, for a relaxing evening of food and fun, sponsored by KPSHA. Bring your lawn chairs, blankets and potluck desserts. Sit back and enjoy music for all ages by David Landeo and fun games for the kids. KPSHA board members and neighborhood watch organizers will be on hand. Calendar year 2007 dues and donations will also be accepted.

Bring a Neighbor, a great way to meet new neighbors and get reacquainted with existing neighbors.

Special thanks to the following sponsors and participants: Krogers, Bush Beans, Foodsales East TN, Calvary Baptist Church.

DON'T FORGET THAT POTLUCK DESSERT, BRING YOUR FAVORITE SWEET!

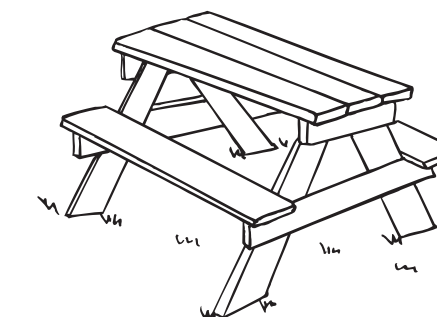

THANK YOU

Special thanks to past president Raleigh Bacon for his work in obtaining historically appropriate replacement streetlights along Cherokee Boulevard. Also, thanks to the city, the Sequoyah Hills Preservation Society and other organizations that made this installation possible.

NEIGHBORHOOD MEMORIAL TREES

Tree Planting: Those wishing to memorialize a loved one will have the opportunity again this winter. Our neighborhood association will accept tree orders using the coupon below. You will be contacted in the fall to discuss a possible location for the placement of your tree in the neighborhood. Please complete the following:

Name _____
Address _____
City/State/Zip Code _____
Tel. Number _____ Email _____

- Circle the tree and color you wish, placing a 1, 2 and 3 next to your choices. (The nursery may be out of your first choice of species. We are following UT's advice on the selection of trees, and expect to plant trees after a solid period of frost, usually in late January or early February.)
- The trees and memorial costs are wholesale prices. Our Association makes no profit on these tree plantings but offers this as a courtesy to our community.
- We are unable to replace trees that die naturally as our wholesale price does not provide a replacement guarantee. However, the City has agreed to replace all memorial trees that were damaged by outside contractors.

Tree Selection: (Mark your 1st, 2nd and 3rd choice)

- ____ Cherry: Yohino (white flowers)
____ Cherry: Kwaazan (showy pink blossoms)
____ Crepe Myrtle: pink, white or lavender blossoms)
____ Dogwood (white or red, only if anthracnose resistant variety available)
____ Redbud (red, white or lavender blooms)
____ Sourwood (white blooms in summer and brilliant fall foliage)

Cost:

| | |
|------------------------|----------|
| ____ Tree and planting | \$255.00 |
| ____ Granite Memorial* | 80.00 |
| Total | \$_____ |

Please make your checks payable to the KP/SHA and mail to:
Kingston Pike/Sequoyah Hills Association
P.O. Box 11762
Knoxville, TN 37939

*Granite Memorial: If you wish to have a granite memorial placed with your tree, please complete the form below. Please note that a maximum of 76 characters can be carved on a stone. (A space is one character.) The more you want written on the stone, the smaller the characters. Please remember that you want to be able to read it standing and looking down at the memorial stone. Use capital letters and print clearly what you want carved in the granite stone:

(Note: Granite memorials will be placed several months after the trees are planted in late winter.)

R-1EN: A NEW MPC ZONING NEIGHBORHOOD MEETING



Date: Thursday, Sept. 27, 2007
Time: 7 p.m.
Location: Sequoyah Presb. Church Hall

**Speaker: Mark Donaldson, Exec. Director
Metropolitan Planning Commission**

- Did you know that the current R-1 zoning that covers most Sequoyah Hills houses allows 4 houses per acre and only requires 7,500 square feet per home site?

Come hear Mark Donaldson, MPC Executive Director, present the details of a new zoning called R1-EN (Established Neighborhood) at an informational session.

- R-1EN was designed with help from Holston Hills residents to meet the needs of established neighborhoods with varied houses, lots of trees, and ongoing development.

- City Council approved this new zoning category on May 22nd. It is intended to provide for neighborhood stability while allowing continued development in harmony with the existing neighborhood pattern.

- The R-1EN zoning requires 22,000 square feet of land (1/2 acre) per home. Allowances are made for vacant lot development, replacement of dilapidated houses, guest apartments, and storage buildings.

- For each house, this zoning requires a minimum depth of the front yard of 40 feet (or equal to the average depth of developed lots on the same street within 500 feet of the subject property).

- Several neighborhoods, including West Hills and Old Westmoreland, are studying the details of R1-EN zoning.

- For more zoning information, go to the MPC website at <http://www.knoxmpc.org>. Click on "Zoning Ordinances and Subdivision Regulations," then click "Zoning Ordinance for Knoxville, TN," followed by Article 4, 2c entitled "R-1EN Established Neighborhood District," pages 80-92.

Mark your calendars for Sept. 27 to hear Mark Donaldson!

LET'S GET TOGETHER!

The size of the KPSHA area can make it hard to know everyone, but quite likely, many of us share similar interests. The KPSHA seeks to help create opportunities ways for members to interact with neighbors on the same street and in the immediate area, as well as the neighborhood as a whole. The association needs volunteers with energy and creativity to organize and promote these opportunities. Fall is just around the corner, the heat is surely about to subside, and there is fun to be had!

Some ideas on the table:

Street or Circle Parties. Did you realize there are 17 distinct neighborhoods in the Seqoyah area? Any excuse is a good one to get together with neighbors for snacks and drinks. We are fortunate in East Tennessee to be able to enjoy four seasons of outdoor fun. Volunteer your front yard for a Friday night get together or a pre-game appetizer swap. Or have a "mixer" with the next street over with games for the smaller kids.

Strut Your Mutt in Sequoyah. Pet pride is contagious, and good times could roll with a friendly competition!

Movie Nights in the Park. "Movie Night in Whitlow" could be an ideal venue for a fall movie night in the park.

Book or Dinner Clubs. If you hate to read or dine alone, others may share common interests and would enjoy sharing ideas over stimulating conversation.

Skill, Expertise or Interest to Share? Maybe computers are your thing, or gardening is your first love. As KPSHA seeks new ways to serve its members, "affinity" groups of neighbors who are interested in sharing information or advice maybe the way to go.

Volunteers are needed to make any of these ideas reality. If you can volunteer to lead or help with a committee to explore these ideas and others, please contact Karen Britton, Membership, britton@utk.edu

MATURE NEIGHBORHOOD TREES

The character of Sequoyah Hills is in large measure the product of the wonderful landscape that surrounds us! Chief among those landscape features are the magnificent large trees that grow in many of our yards. Some of these trees are approaching the end of their lives as they were here when Sequoyah Hills was planned in the 1920s or planted soon after.

Have you noticed how many trees are being taken down? Lately it seems that every block is ringing with the sounds of chain saws as the great oaks succumb to age. The character of our community will change from this gracious leafy canopy to one of a continuous belt of lawns unless we replace them. The Kingston Pike/Sequoyah Hills Association would like to encourage you to replant these great trees! Replanting these large trees will ensure the gracious beauty of your property and this community for future generations, and they will add value to your property!

Tree Pamphlet: We still have a few free copies available of "Recommended Trees for the Kingston Pike/Sequoyah Hills Residential Area" by Ed Buckner, Tom Simpson and Nancy Bills. If you would like a copy, please email your request to JBLETNER@utk.edu.



ENGLISH IVY IS KILLING MAJESTIC OLD TREES IN SEQUOYAH HILLS!



English ivy is the most prevalent and harmful of all vines in your yard. Though some may feel it looks nice, it is a killer in the making.

- ALL trees covered in ivy will eventually die and are more likely topple in storms.
- One large tree, uncared for, can result in removal fees in the thousands of dollars.
- Ivy holds moisture and absorbs nitrogen basically rotting/starving the host tree.
- Ivy can transmit bacterial leaf scorch that kills Elms, Oaks and Maples.
- Ivy is NOT a good erosion control due to shallow roots.
- Ivy's fast growth forces out native plants and seedlings. So much so several states are legislating to ban English Ivy.
- Trees covered in ivy reduce property values and can be breeding grounds for rats and mice.
- Ivy is easily controlled by cutting a 12" gap in the taproots all around the base of the tree; the vine cannot live without soil. Be careful not to cut into life sustaining tree bark. To prevent re-growth, pull up a 3-6 foot circle of roots around the tree.
- Mature trees require 10 gallons of water per week per inch of trunk diameter, with current drought conditions; ivy is robbing these trees of essential water.

For more information please contact Allen Senter Tate, a.tate@comcast.net or 300-2537 or call a tree service for removal.